

PROUDLY MADE IN FLORIDA, USA BY

Tarps4Trucks

a *Cosner Mfg.* company



Product Guide February 2022



Tarps4Trucks

a *Cosner Mfg.* company

Motors	13-14
Tarps	3-12
Dump Truck Tarps	3-8
Mega Mesh™	4
Multi-Color PVC Mesh.....	5
Black PVC Mesh	6
Asphalt Tarps	7-8
18oz Vinyl - with and without flaps	7
Asphalt Lumite	8
Waste or Trash Tarps	9-10
Roll-Off tarp system replacement tarps	9
Hand tarps, Compactor Diapers, Bungee Straps	10
Special tarp pricing – estimate your custom tarp cost	12
Tarp repair	12
Lumber tarp sizes and Pricing	12
Parts and Mechanisms	13-23
Replacement Parts	14-15
Motors, Switches, Springs, Tarp Axles, etc.	
Complete Head Assemblies, manual	16-17
Cab Level Head Assembly	16
Ground Level Head Assembly	17
Complete Head Assemblies, electric	18-19
Head Assembly Parts	18
Electric Head Assemblies	19
Conversion kits	20-21
Ground Level Conversion Kit	20-21
Electric Conversion Kits	20-21
Galvanized Steel Tarp System	23
Polished Aluminum 4-Spring Tarp System	24-25
Aero Aluminum Tarp System	26-27
Heavy Duty Polished Aluminum Tarp System	28-29
Order Forms	30-33
Switch Wiring Diagrams	34
Policies	35

Welcome!



1	Head Assembly
2	Tarp Axle
3	Tarp
4	Arm Set

5	Rear Cross Piece
6	Upper Arm
7	Lower Arm

Basic tarp terms . . .

• Denier:

- Is the uncoated weight in grams of 9000 meters of yarn. 1000 denier yarn is ~20% stronger than 800 denier yarn. American Made material is mainly 1000 denier or higher whereas imported mesh is mostly made with 800 denier.

• Thread Count:

- Is the number of yarns per inch. The industry standard for the last 50 years has been a 11x11 with black and Multi-colored PVC coated mesh made with 1000 denier yarn.

• Air Flow:

- This is how much air can pass through the material and can have a big effect on the life of the material. If the material flaps around excessively the material will have issues earlier than if the material did not flap. Flapping is what usually kills vinyl tarps since no air passes through them.



*Great for hauling the roughest of loads!
C&D, Trash, Landscape Debris, etc...*

7' wide, color will vary

7' 6" wide, color will vary

Part #	W x L	Weight (lbs)
TMEG710	7' x 10'	9.68
TMEG712	7' x 12'	11.44
TMEG714	7' x 14'	13.20
TMEG716	7' x 16'	14.96
TMEG718	7' x 18'	16.72
TMEG720	7' x 20'	18.48
TMEG722	7' x 22'	20.24
TMEG724	7' x 24'	22.00
TMEG726	7' x 26'	23.76
TMEG728	7' x 28'	25.52
TMEG730	7' x 30'	27.28
TMEG732	7' x 32'	29.04
TMEG734	7' x 34'	30.8
TMEG736	7' x 36'	32.56
TMEG738	7' x 38'	34.32
TMEG740	7' x 40'	36.08

Part #	W x L	Weight (lbs)
TMEG7610	7' 6" x 10'	10.2
TMEG7612	7' 6" x 12'	12.1
TMEG7614	7' 6" x 14'	14.0
TMEG7616	7' 6" x 16'	15.8
TMEG7618	7' 6" x 18'	17.7
TMEG7620	7' 6" x 20'	19.6
TMEG7622	7' 6" x 22'	21.5
TMEG7624	7' 6" x 24'	23.3
TMEG7626	7' 6" x 26'	25.2
TMEG7628	7' 6" x 28'	27.1
TMEG7630	7' 6" x 30'	28.9
TMEG7632	7' 6" x 32'	30.8
TMEG7634	7' 6" x 34'	32.56
TMEG7636	7' 6" x 36'	34.32
TMEG7638	7' 6" x 38'	36.08
TMEG7640	7' 6" x 40'	37.84

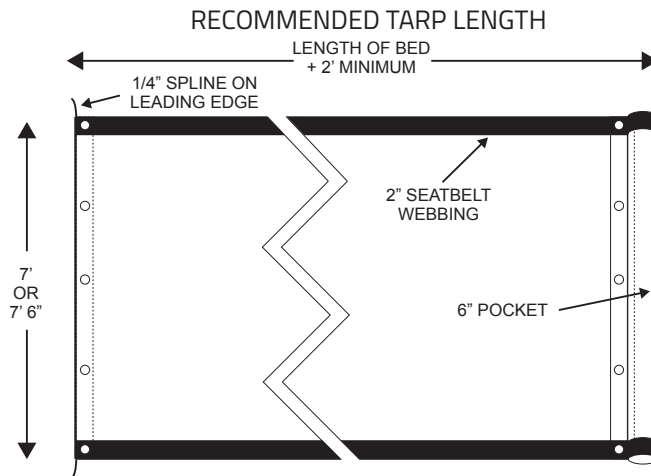

Stock Mega Mesh™ Tarp Specifications:

- Color Varies • Double folded hem • 6" pocket
- Spline on front edge of tarp • Full length seatbelt webbing on side hems
- Best Dump Truck Tarp material on the market!
- More than twice the tear strength of standard mesh products

Other Mesh materials available:

- HD Solid Color PVC Mesh: Black, Green, Red, Blue
 - Multi-Color Mesh – lower cost alternative, color varies
 - Waterproof Materials available!
- Need Something else? Give us a call – (863) 676-2579

Multi-Color PVC Mesh stock tarps

7' wide, color will vary

Part #	W x L	Weight (lbs)
T4630	7' x 10'	6.4
T4631	7' x 12'	7.7
T4632	7' x 14'	9.0
T4633	7' x 16'	10.3
T4634	7' x 18'	11.6
T4635	7' x 20'	12.9
T4636	7' x 22'	14.2
T4637	7' x 24'	15.5
T4638	7' x 26'	16.7
T4639	7' x 28'	18.0
T4640	7' x 30'	19.3
T4670	7' x 32'	20.6
T4671	7' x 34'	21.9
T4672	7' x 36'	23.2
T4673	7' x 38'	24.5
T4674	7' x 40'	25.8

7' 6" wide, color will vary

Part #	W x L	Weight (lbs)
T4641	7' 6" x 10'	6.8
T4642	7' 6" x 12'	8.1
T4643	7' 6" x 14'	9.5
T4644	7' 6" x 16'	10.9
T4645	7' 6" x 18'	12.2
T4646	7' 6" x 20'	13.6
T4647	7' 6" x 22'	15.0
T4648	7' 6" x 24'	16.4
T4649	7' 6" x 26'	17.6
T4650	7' 6" x 28'	19.3
T4651	7' 6" x 30'	20.4
T4652	7' 6" x 32'	21.7
T4653	7' 6" x 34'	23.1
T4654	7' 6" x 36'	24.5
T4655	7' 6" x 38'	25.9
T4656	7' 6" x 40'	27.2

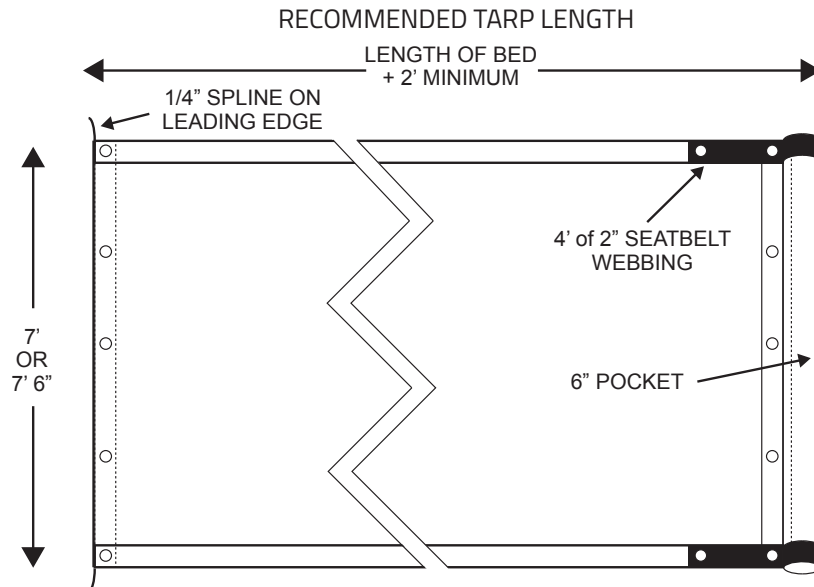

Stock Multi-Color PVC Mesh Tarp Specifications:

- Double folded hem • 6" pocket
- Spline on front edge of tarp • 4' of seatbelt around the pocket
- Seatbelt webbing the entire length • Vinyl reinforced pocket

Additional options:

Other Mesh materials available:

- Mega Mesh™ – super strong, color varies
 - Solid Color Mesh available: Black, Red, Green, and Blue
 - Waterproof materials available
- Need Something else? Give us a call – (863) 676-2579



Heavy Duty Black PVC Mesh stock tarps

7" wide

7" 6" wide

Part #	W x L	Weight (lbs)
T681	7' x 10'	6.7
T3598	7' x 12'	8.1
T3599	7' x 14'	9.4
T3600	7' x 16'	10.8
T3601	7' x 18'	12.1
T3602	7' x 20'	13.4
T4015	7' x 22'	14.8
T3968	7' x 24'	16.1
T4016	7' x 26'	17.5
T4258	7' x 28'	18.8
T4257	7' x 30'	20.2
T683	7' x 32'	21.5

Part #	W x L	Weight (lbs)
T5	7' 6" x 10'	7.1
T6	7' 6" x 12'	8.5
T7	7' 6" x 14'	9.9
T8	7' 6" x 16'	11.3
T9	7' 6" x 18'	12.7
T10	7' 6" x 20'	14.1
T11	7' 6" x 22'	15.6
T12	7' 6" x 24'	17.0
T13	7' 6" x 26'	18.4
T2152	7' 6" x 28'	19.8
T15	7' 6" x 30'	21.2
T16	7' 6" x 32'	22.6

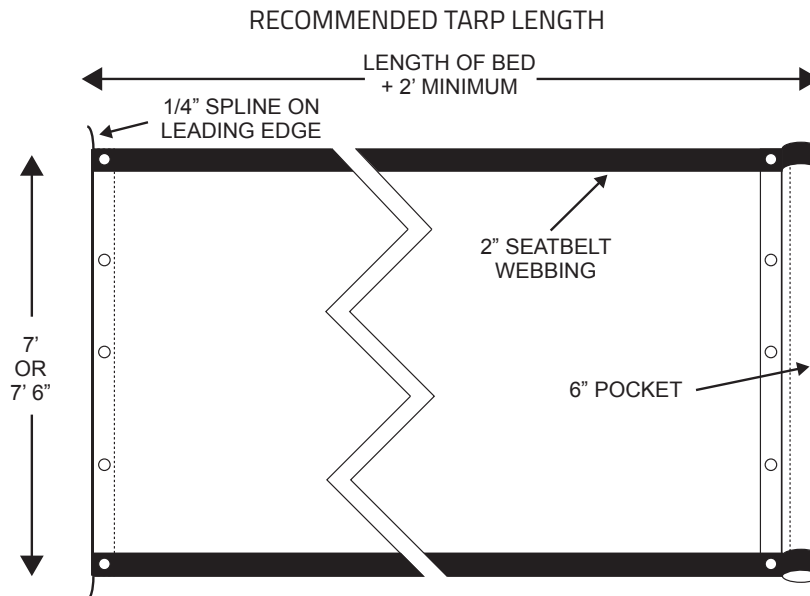

Stock Black PVC Mesh Tarp Specifications:

- Double folded hem • 6" pocket • Spline on front edge of tarp
- Seatbelt webbing sewn over side hems the entire length of the tarp

Additional option:

- Vinyl reinforced pocket

Other Mesh materials available:

- Mega Mesh™ – super strong, color varies
 - Solid Color Mesh available: Black, Red, Green, and Blue
 - Waterproof materials available
- Need Something else? Give us a call – (863) 676-2579

Asphalt Tarps

18 oz. Black Vinyl Front-to-Rear Tarps (Waterproof)

Vinyl Tarps, no Flaps

Part #	W x L	Weight (lbs)
T1756	7' x 10'	12.7
T1757	7' x 12'	14.9
T1758	7' x 14'	17.1
T1759	7' x 16'	19.3
T1760	7' x 18'	21.5
T1761	7' x 20'	23.7
T1762	7' x 22'	25.9
T1763	7' x 24'	28.1
T1764	7' x 26'	30.3
T955	7' 6" x 10	13.4
T956	7' 6" x 12	15.8
T957	7' 6" x 14	18.1
T958	7' 6" x 16	20.5
T959	7' 6" x 18	22.8
T960	7' 6" x 20	25.1
T961	7' 6" x 22	27.5
T962	7' 6" x 24	29.8
T963	7' 6" x 26	32.1

Vinyl Tarps, with Flaps + shock cord

7' or 7' 6" wide PLUS 1' Flaps on each side, includes 5/16" cord

Part #	Width of Tarp	Length of Bed	Weight (lbs)
T4319	9'	10'	15.8
T4320	9'	12'	18.6
T4321	9'	14'	21.3
T4323	9'	16'	24.1
T4324	9'	18'	26.8
T4325	9'	20'	29.6
T4326	9'	22'	32.3
T4327	9' 6"	10'	16.6
T4328	9' 6"	12'	19.5
T4329	9' 6"	14'	22.4
T4322	9' 6"	16'	25.3
T2971	9' 6"	18'	28.2
T2972	9' 6"	20'	31.0
T2973	9' 6"	22'	33.9

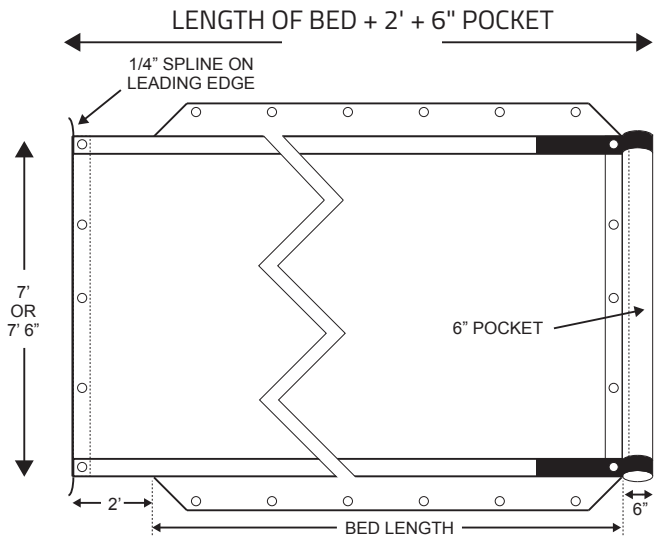
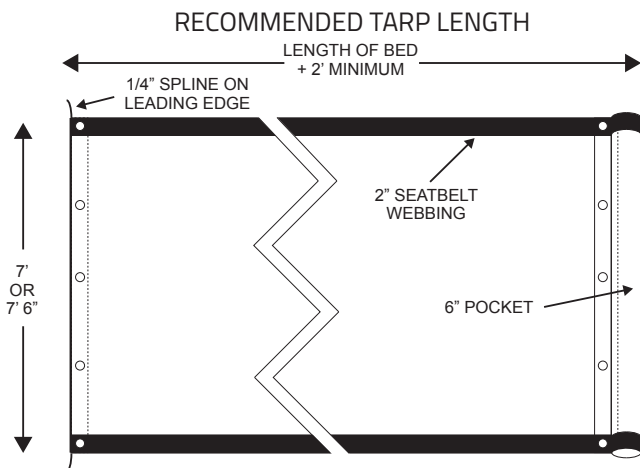

Stock Tarp Specifications:

- Double folded hem
 - 6" pocket
- Spline sewn into front hem
- Grommets on the edges of tarp flaps, 4' spacing

Options for waterproof tarps

- 18 oz Vinyl available in Black, Blue, Red, Green, Yellow, Orange, White
 - 22 oz vinyl available upon request
- Air Bag, RFL & Asphalt Lumite are light weight, semi-waterproof alternatives
Need Something else? Give us a call – (863) 676-2579



Asphalt Tarps Asphalt Lumite Tarps* 99% Waterproof

Part #	Description	W x L	Weight (lbs)
T1835	7' x 12' Asphalt Lumite Tarp	7' x 12'	4.6
T1836	7' x 14' Asphalt Lumite Tarp	7' x 14'	5.4
T1837	7' x 16' Asphalt Lumite Tarp	7' x 16'	6.2
T1838	7' x 18' Asphalt Lumite Tarp	7' x 18'	7.0
T1839	7' x 20' Asphalt Lumite Tarp	7' x 20'	7.7
T1840	7' x 22' Asphalt Lumite Tarp	7' x 22'	8.5
T1841	7' x 24' Asphalt Lumite Tarp	7' x 24'	9.3
T1842	7' x 26' Asphalt Lumite Tarp	7' x 26'	10.0
T684	7' 6" x 10' Asphalt Lumite Tarp	7' 6" x 10'	3.9
T395	7' 6" x 12' Asphalt Lumite Tarp	7' 6" x 12'	4.6
T396	7' 6" x 14' Asphalt Lumite Tarp	7' 6" x 14'	5.4
T397	7' 6" x 16' Asphalt Lumite Tarp	7' 6" x 16'	6.2
T398	7' 6" x 18' Asphalt Lumite Tarp	7' 6" x 18'	7.0
T399	7' 6" x 20' Asphalt Lumite Tarp	7' 6" x 20'	7.7
T400	7' 6" x 22' Asphalt Lumite Tarp	7' 6" x 22'	8.5
T4260	7' 6" x 24' Asphalt Lumite Tarp	7' 6" x 24'	9.3
T4261	7' 6" x 26' Asphalt Lumite Tarp	7' 6" x 26'	10.0

* Black only

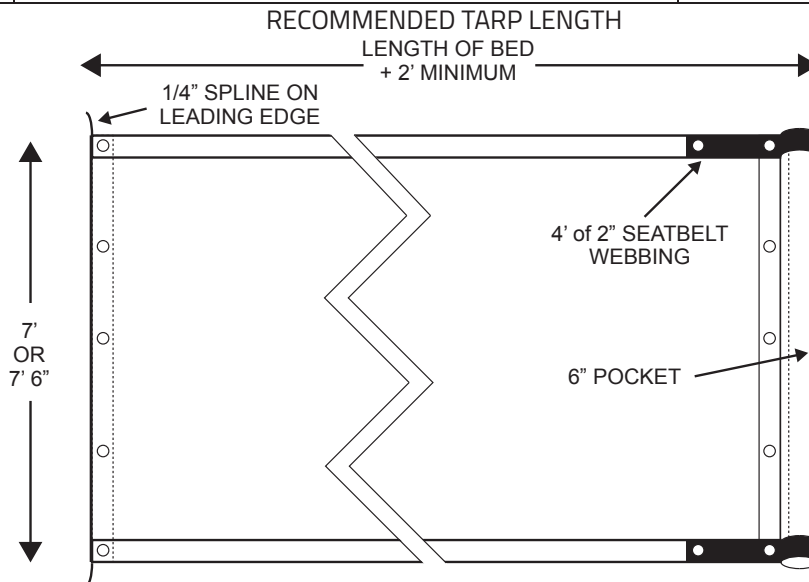

Stock Tarp Specifications:

- Double folded hem
 - 6" Pocket
- Spline sewn into front edge of tarp
- Tarp should be 2' longer than truck body

Material information:

- Airbag is a good alternative to Asphalt Lumite
- Vinyl is the only 100% waterproof tarp material we offer
- Asphalt Haulers Prefer: Vinyl, RFL, Airbag, and Asphalt Lumite

Auto-Tarps for roll-off trucks - Mega Mesh™

Part #	Description	W x L	Weight (lbs)
T4396	Pioneer Style, 9' 8" x 28' w/ 12" self-retracting flaps & shock cord Mega Mesh™	9' 8" x 28'	36.0
T4465	Universal 8' x 28' Mega Mesh™ w/ seatbelt webbing	8' x 28'	30.0
TMEG828	8'x28' f/s roll-off tarp - no fold hem w/ seatbelt webbing	8' x 28'	30.0
T4399	O'Brian Style 9' 6" x 28' w/ 11" flaps & tapered ends Mega Mesh™	9' 6" x 28'	36.0
T1905	Pioneer Style, 9' 6" x 28' w/ 9" flaps & tapered ends Mega Mesh™	9' 6" x 28'	36.0

PART # 4396

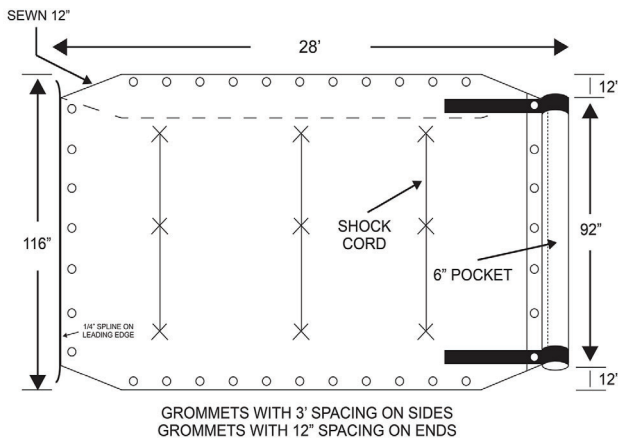

PART # 4465

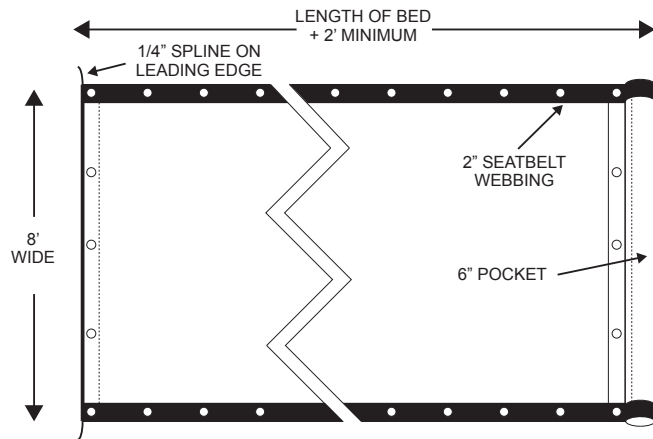

PART # TMEG828

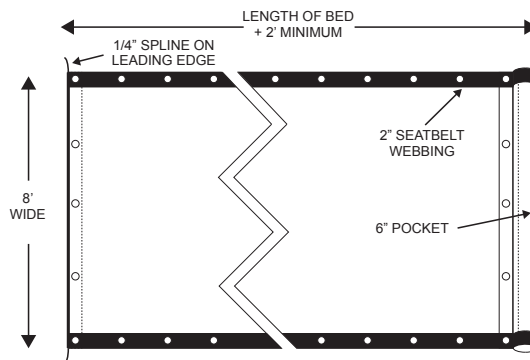

PART # 4399

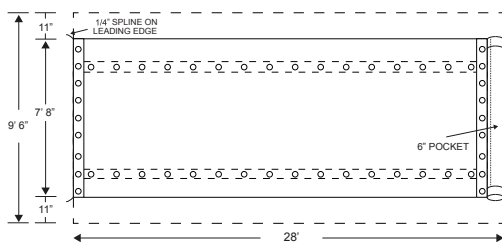

PART # 1905

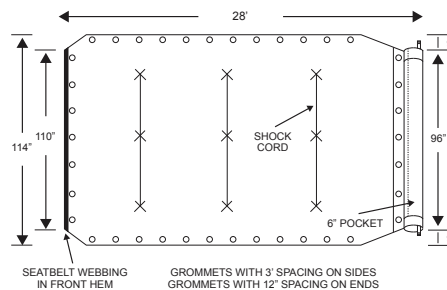



Hand Tarps, Sod Tarps, Tree Tarps (no pockets)

Part #	Description	W x L	Weight (lbs)
T4017	12'x18' Multi-Color Mesh hand tarp	12' x 18'	11.3
T4170	12'x24' Multi-Color Mesh hand tarp	12' x 24'	14.9
T4171	12'x26' Multi-Color Mesh hand tarp	12' x 26'	16.0
T4013	12'x18' 70% Knitted Mesh, Black, hand tarp	12' x 18'	11.0
T2892	12'x24' 70% Knitted Mesh, Black, hand tarp	12' x 24'	14.5
T2893	12'x26' 70% Knitted Mesh, Black, hand tarp	12' x 26'	15.6
T1245k	12'x45' 70% Knitted Mesh, Black, hand tarp	12' x 45'	25.8
T1248k	12'x48' 70% Knitted Mesh, Black, hand tarp	12' x 48'	27.5
T1250k	12'x50' 70% Knitted Mesh, Black, hand tarp	12' x 50'	28.5
T1253k	12'x53' 70% Knitted Mesh, Black, hand tarp	12' x 53'	32.0
T3844	12'x24' - 18oz vinyl, no pocket, hem and grommets all 4 sides	12' x 24'	39.4
T3845	12'x26' - 18oz vinyl, no pocket, hem and grommets all 4 sides	12' x 26'	42.5

**Custom TREE TARPS and BEE NETS available upon request*

Compactor Diapers

Mesh Compactor Diapers

Part #	Description	Weight (lbs)
T82	5'x7' - no pocket, hem & grommets all sides	5.0
T83	6'x8' - no pocket, hem & grommets all sides	6.0

Waterproof Compactor Diapers

Part #	Description	Weight (lbs)
T84	5'x7' - 18oz vinyl, no pocket, hem & grommets all sides	8.0
T85	6'x8' - 18oz vinyl, no pocket, hem & grommets all sides	9.0

Rubber Bungee Cord Straps

Part #	Description	Weight (lbs)
T15BC	15" Rubber Bungee Strap	12.0
T21BC	21" Rubber Bungee Strap	14.0
T31BC	31" Rubber Bungee Strap	18.0
T41BC	41" Rubber Bungee Strap	24.0

Tarp Materials . . .

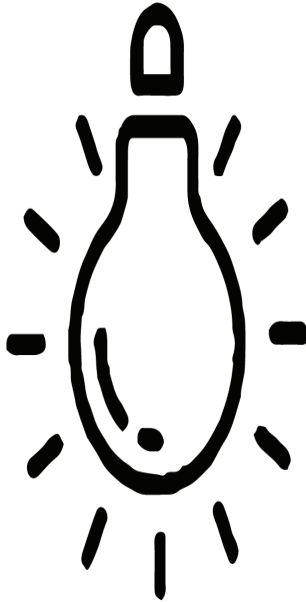

- **Multi-Color Mesh:** Tarps4Trucks uses a 1000 denier yarn. Our standard construction is 14x14. We also offer an industry standard 11x11 construction for price conscious customers. We prefer to offer better than every else, but we don't want price to send our customers to imported tarps. Our tarps are Made in America, your welcome to visit us in Sunny Lake Wales Florida
- **Black Mesh** – Tarps4Trucks offers an 11x11 1000 denier Black Mesh. Most of our competitors sell imported pre-made tarps and use an 11x11 (or even a 10x10) mesh made with 800 denier yarns. Black Mesh is great for customer selling new trucks or trailers because they demand solid black. If color is not critical, we recommend Mega Mesh which is ~3x stronger than Black mesh but costs about the same.
- **Mega Mesh** - all 1000 denier with a 20x20 construction. Best truck tarp material on the market. Tarps4trucks has Mega Mesh Material made specially for us by an American Manufacturer. We designed this material to be used on Roll-off trucks and it has become our bestselling dump truck material also. It has the perfect combination of yarn strength and air flow to work in the toughest of applications.
- **Seatbelt webbing** – Tarps4Trucks sews Automotive Quality Seat belt webbing with a strength of 6000 lbs. down the sides of all our tarps to reinforce our tarps and pockets. Our competitors use mostly 500lb webbing that is 2" wide but is mainly for looks. We are happy to compare our American made products with our competitors tarps any day!

DID YOU KNOW?



Special Tarp Pricing

Material	Material Widths
Mega Mesh™	8' and 10'
Standard Multi-Color PVC Mesh *	8'
Heavy Duty Black PVC Mesh	8'
18 oz Vinyl	60"
RFL **	Varies
Airbag	70"
Asphalt Lumite	8' and 12'
Black 70% Knitted Mesh	10', 12', and 20'

* Color will vary ** Weight will vary

Note: To estimate a special tarp price, multiply (Width + 1') x (Length + 1') to get square feet. Additional features will be charged accordingly; i.e. extra row of webbing, vinyl reinforced pockets, or boxed ends, etc.

Tarp Repair

Part	Description
THH66	HH-66 Tarp repair Glue (16oz)
THH66kit	Tarp repair kit (16oz HH-66 Glue and 25 sq vinyl*)



Lumber Tarps

Part	Description	W x L	Weight (lbs)
T20X27BLACKLT	Lumber tarp, 6' drop; two tarps = one set	20' x 27'	85.0
T24X27BLACKLT	Lumber tarp, 8' drop; two tarps = one set	24' x 27'	108.0
T16X27BLACKST	Steel Tarp	16' x 27'	65.0

*No free freight on Lumber Tarps ** Special sizes and colors available upon request

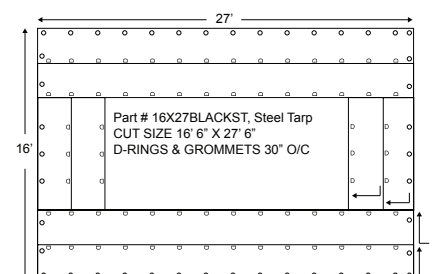
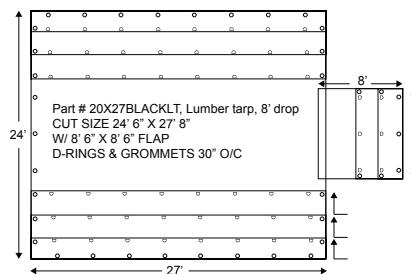
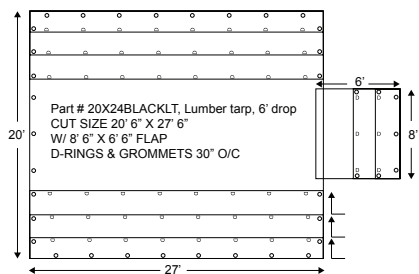

Tarp Motors

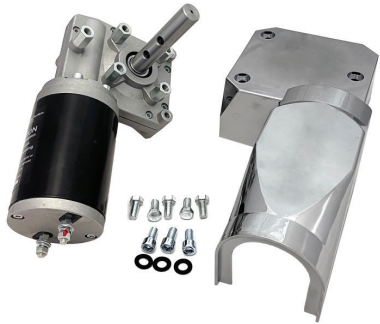

P-M50 - 50:1 Direct Drive Motor

Faster, less power, up to 23' bodies



P-M60 - 60:1 Direct Drive Motor

Moderate speed and power, up to 36' - 40' bodies



P-M90 - 90:1 Direct Drive Motor

Slower and more powerful, 40' + bodies

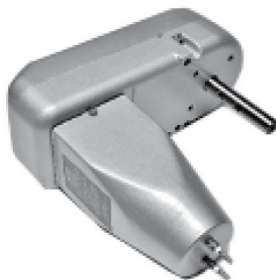

P-MSD - Super Duty Direct Drive Motor

Super Duty motor for any body length

* Images are subject to change



Tarp System Parts

Motors

P-M50	Motor 50:1 w/1.5hp motor
P-M60	Motor 60:1 w/1.5hp motor
P-M90	Motor 90:1 w/2hp motor
P-MSD	Motor 60:1 w/2hp motor
P-MC5	Chrome motor cover, cover only - for 50:1 motor
P-MC6	Chrome motor cover, cover only - for 60:1 motor & 90:1 motor
P-1002	Hardware bag for GL and Motor

Switches (see wiring diagram on page 31)

Rotary or Barrel Switch

A	P-500B	Rotary (Barrel) Switch Kit
1	P-510B	Rotary Switch - Rotary (Barrel) switch only
2	P-440	40 Amp Manual Circuit Breaker
3	P-450	50 Amp Automatic in-line Breaker

(A) Rotary or Barrell Switch Kit

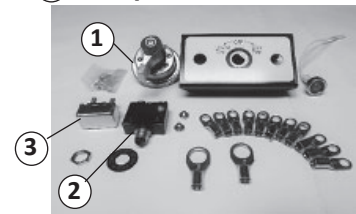

Trombetta Style Switch parts

B	P-600T	Trombetta Weatherproof Reverse Polarity Solenoid Kit
6	P-610T	Trombetta 12V Dual Contractor -switch box only
3	P-450	50 Amp Automatic in-line Breaker
4	P-430	Rocker Switch

(B) Trombetta Switch Kit

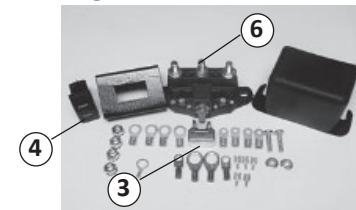

Relay Style Switch parts

C	P-700R	Relay Switch Kit
5	P-710R	Relay -switch box only
3	P-450	50 Amp Automatic in-line Breaker
4	P-430	Rocker Switch

(C) Relay Switch Kit

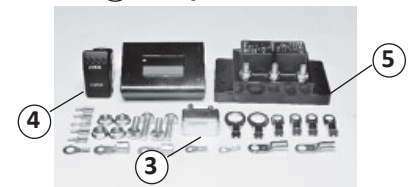

Wire

P-W6-1ft	6ga. Dual Conductor Wire, per ft
P-W50ft	6ga. Dual Conductor Wire, 50ft put-up
P-W65ft	6ga. Dual Conductor Wire, 65ft put-up
P-W500ft	6ga. Dual Conductor Wire, 500 ft put-up
P-WQDV-V	TRAILER QUICK DISCONNECT -set vertical metal 2 prong
P-WQDV-socket	TRAILER QUICK DISCONNECT socket only- vertical metal 2 prong
P-WQDV-plug	TRAILER QUICK DISCONNECT plug only- vertical metal 2 prong
P-WQD-H	TRAILER QUICK DISCONNECT -set horizontal metal 2 prong
P-WQDH-socket	TRAILER QUICK DISCONNECT socket only- horizontal metal 2 prong
P-WQDH-plug	TRAILER QUICK DISCONNECT plug only- horizontal metal 2 prong
P-WQDP	Plastic - TRAILER QUICK DISCONNECT - plastic 2 prong - need two as a set



Universal Replacement Parts

**See Head Assembly drawing on pages 14-17 for parts and pieces
* See System drawings on pages 20-23 for system specific parts*

Springs

P-S121	Spiral Torsion Spring
P-619550	Aero Side Mount Double Torsion Spring

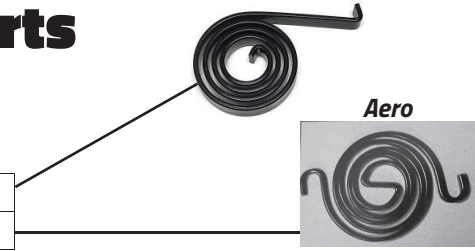

Tarp Axle

P-1120	Tarp Axle kit: QTY 1 - adjustable aluminum tarp axel, 1-3/4" stub shaft, 2- 3/4" bearings and 2 - Aluminum Bearing Plates
P-1111	Tarp axel only, adjustable 93"-110" - Picture on page 15, #4
P-1120HD	Tarp Axle kit Heavy Duty: QTY 1 - HD aluminum tarp axel, 1-3/4" stub shaft, 2- 3/4" bearings and 2 - Aluminum Bearing Plates
P-1111HD	Tarp Axle only, 103" - HD tarp axel - Picture on page 15, #5

**the Adjustable tarp axel can be shipped in 48" box*

Bearing Plates

P-1018A	Aluminum Bearing plate - Picture on page 15, #1
P-1018S	Small Bearing plate - steel - Picture on page 14, #10

Bearings, 3/4"

P-1015	Bearing, 3/4in flange - Picture on page 15, #3
P-1016	Bearing, 3/4in floor mount - Picture on page 14
P-1017	Bearing, 3/4in wall mount - Picture on page 14

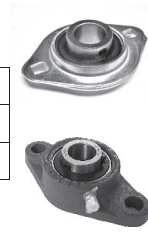

3/4" Shafts

P-1019	3/4" Stub shaft with hole - Picture on page 15, #2
P-1013	Sprocket with 3/4" shaft - Picture on page 15, #7

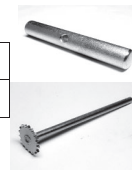

Crank Handles & Parts

P-1020	Cab level crank handle - Picture on page 15, #9
P-1012	GL Crank box - only - Picture on page 15, #6
P-1013	Sprocket with 3/4" shaft - only - Picture on page 15, #7
P-1014	12' chain - only - Picture on page 15, #8



Wind Deflectors

P-1710	Aluminum Wind Deflector 103" w/Mounting Bracket kit for systems - Picture on Page 18, #9
P-1720	92" Aluminum Housing
P-1725	98" Aluminum Housing
P-1729	Housing bracket one - 2-4 needed radius max 3



Complete Head assemblies - Manual

Page Bearing Plates
Stub Shaft 3/4"
Bearing 3/4"
Cab Level Crank Handle
Ground level crank box
Shaft 3/4" w/sprocket
12' Chain
Adjustable tarp axel
HD tarp Axel 103"

P-1400A	Cab Level head assembly, Adjustable Tarp Axel	14	2	1	2	1				1	
P-1400H	Cab Level head assembly, HD roller Tarp Axel	14	2	1	2	1					1
P-1500A	Ground Level head assembly, Adjustable Tarp Axel	15	2	1	2		1	1	1	1	
P-1500H	Ground Level head assembly, HD Tarp Axel	15	2	1	2		1	1	1		1

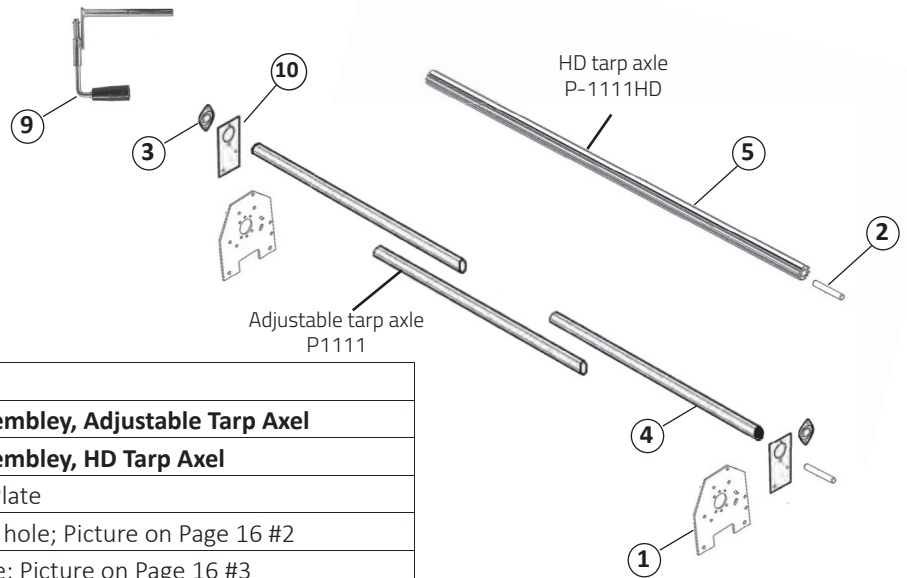

Cab Level Head Assembly

#	Part #	Description
	P-1400A	Cab Level head assembly, Adjustable Tarp Axel
	P-1400H	Cab Level head assembly, HD Tarp Axel
1	P-1018A	Aluminum Bearing Plate
2	P-1019	3/4" Stub shaft with hole; Picture on Page 16 #2
3	P-1015	Bearing, 3/4in flange; Picture on Page 16 #3
4	P-1111	Tarp axel only, adjustable 93"-110"; Picture on Page 16 #4
5	P-1111HD	HD Tarp Axle, 103" - Picture on Page 16 #5
9	P-1020	Cab Level Crank Handle, Picture on Page 16 #9
10	P-1018S	Small Bearing plate - steel; Page 14 #10

3/4" Bearings



P-1015
Bearing, 3/4in flange



P-1016
Bearing, 3/4in floor mount



P-1017
Bearing, 3/4in wall mount

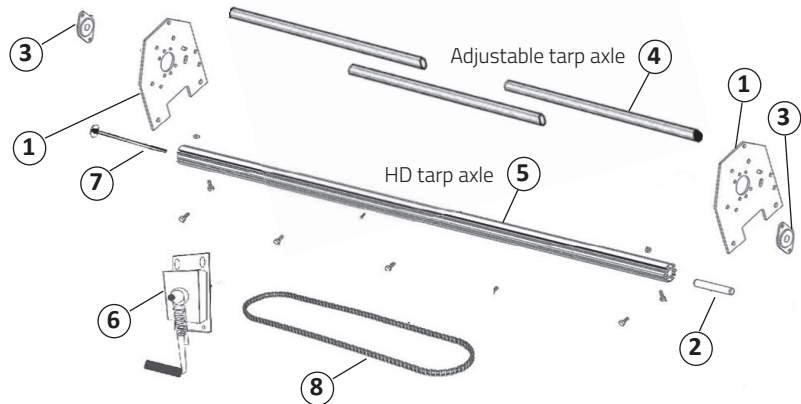

Ground Level Head Assembly

#	Part #	Description
	P-1500A	Ground Level head assembly, Adjustable Tarp Axel
	P-1500H	Ground Level head assembly, HD Tarp Axel
1	P-1018A	Aluminum Bearing plate
2	P-1019	3/4" Stub shaft with hole; Picture on Page 15 #2
3	P-1015	Bearing, 3/4in ange; Picture on Page 15 #3
4	P-1111	Tarp axel only, adjustable 93"-110"; Picture on Page 15 #4
5	P-1111HD	HD Tarp Axle only, 103" - Picture on Page 15 #5
6	P-1012	GL Crank box
7	P-1013	Sprocket with 3/4" shaft
8	P-1014	12' chain
9	P-1020	Cab Level Crank Handle, Picture on Page 15 #9
10	P-1018S	Small Bearing plate; Page 14 #10

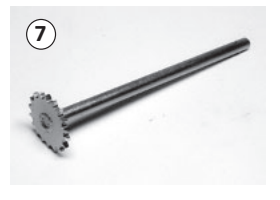
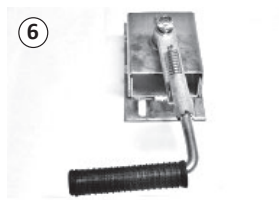
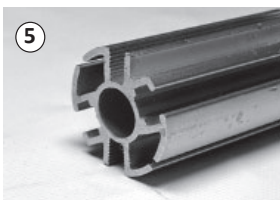
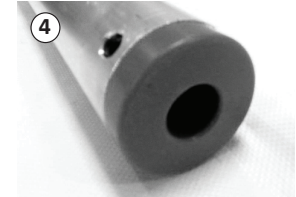
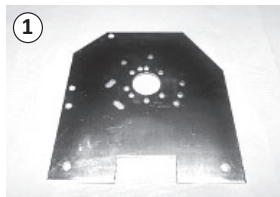



Complete Head assemblies - Electric (EL)

page Bearing Plates
Stub Shaft 3/4"
Bearing 3/4"
Adjustable tarp axel
HD tarp Axel 103"
Barrel switch kit
Trombetta switch kit
Relay switch kit
50:1 Motor
60:1 Motor
90:1 Motor
50' wire

50:1 Motors													
P-1600AB5	Electric head assembly: Adjustable Tarp Axel	17	2	1	1	1		1			1		1
P-1600HB5	Electric head assembly, HD Tarp Axel, Barrel Switch	17	2	1	1		1	1			1		1
P-1600AT5	Electric head assembly, Adjustable Tarp Axel	17	2	1	1	1			1		1		1
P-1600HT5	Electric head assembly, HD Tarp Axel	17	2	1	1		1		1		1		1
P-1600AR5	Electric head assembly, Adjustable Tarp Axel	17	2	1	1	1				1	1		1
P-1600HR5	Electric head assembly, HD Tarp Axel	17	2	1	1		1			1	1		1
60:1 Motors													
P-1600AB6	Electric head assembly, Adjustable Tarp Axel	17	2	1	1	1		1				1	1
P-1600HB6	Electric head assembly, HD Tarp Axel	17	2	1	1		1	1				1	1
P-1600AT6	Electric head assembly, Adjustable Tarp Axel	17	2	1	1	1			1			1	1
P-1600HT6	Electric head assembly, HD Tarp Axel	17	2	1	1		1		1			1	1
P-1600AR6	Electric head assembly, Adjustable Tarp Axel	17	2	1	1	1				1		1	1
P-1600HR6	Electric head assembly, HD Tarp Axel	17	2	1	1		1			1		1	1
90:1 Motors													
P-1600AB9	Electric head assembly, Adjustable Tarp Axel	17	2	1	1	1		1				1	1
P-1600HB9	Electric head assembly, HD Tarp Axel	17	2	1	1		1	1				1	1
P-1600AT9	Electric head assembly, Adjustable Tarp Axel	17	2	1	1	1			1			1	1
P-1600HT9	Electric head assembly, HD Tarp Axel	17	2	1	1		1		1			1	1
P-1600AR9	Electric head assembly, Adjustable Tarp Axel	17	2	1	1	1				1		1	1
P-1600HR9	Electric head assembly, HD Tarp Axel	17	2	1	1		1			1		1	1

Head Assembly parts - see next page (18) for drawing

1	P-1018A	Aluminum bering plate - Picture on page 15, #1
2	P-1019	3/4" Stub shaft with hole - Picture on page 15, #2
3	P-1015	Bearing, 3/4in flange - Picture on page 15, #3
4	P-1111	Tarp axel only, adjustable 93"-110" - Picture on page 15, #4
5	P-1111HD	Tarp Axle only, 103" - HD tarp axel - Picture on page 15, #5
6	P-500B	Rotary (Barrel) Switch Kit - Picture on page 12, #A
6	P-600T	Trombetta Weatherproof Reverse polarity solenoid -complete kit - Picture on page 12, #B
6	P-700R	Relay Switch kit - complete kit - Picture on page 12, #C
7	Page 12	12v direct drive tarp motor - See motors on page 12
8	Page 12	Motor cover - See motors on page 12
9	P-1710	Aluminum Wind deflector 103" w/Mounting Bracket kit for systems (optional)

Electric Head Assemblies with 50:1 Motor

P-1600AB5	Electric head assembly: Adjustable Tarp Axel, Barrel Switch, 50:1 motor, 50' wire
P-1600HB5	Electric head assembly, HD Tarp Axel, Barrel Switch, 50:1 motor, 50' wire
P-1600AT5	Electric head assembly, Adjustable Tarp Axel, Trombeta Switch, 50:1 motor, 50' wire
P-1600HT5	Electric head assembly, HD Tarp Axel, Trombeta Switch, 50:1 motor, 50' wire
P-1600AR5	Electric head assembly, Adjustable Tarp Axel, Relay switch, 50:1 motor, 50' wire
P-1600HR5	Electric head assembly, HD Tarp Axel, Relay switch, 50:1 motor, 50' wire

* Each kit includes: (1) Stub Shaft 3/4", (1) Bearing 3/4", (2) Bearing Plates

Electric Head Assemblies with 60:1 Motor

P-1600AB6	Electric head assembly, Adjustable Tarp Axel, Barrel Switch, 60:1 motor, 50' wire
P-1600HB6	Electric head assembly, HD Tarp Axel, Barrel Switch, 60:1 motor, 50' wire
P-1600AT6	Electric head assembly, Adjustable Tarp Axel, Trombeta Switch, 60:1 motor, 50' wire
P-1600HT6	Electric head assembly, HD Tarp Axel, Trombeta Switch, 60:1 motor, 50' wire
P-1600AR6	Electric head assembly, Adjustable Tarp Axel, Relay switch,, 60:1 motor, 50' wire
P-1600HR6	Electric head assembly, HD Tarp Axel, Relay switch, 60:1 motor, 50' wire

* Each kit includes: (1) Stub Shaft 3/4", (1) Bearing 3/4", (2) Bearing Plates

Electric Head Assemblies with 90:1 Motor

P-1600AB9	Electric head assembly, Adjustable Tarp Axel, Barrel Switch, 90:1 motor, 50' wire
P-1600HB9	Electric head assembly, HD Tarp Axel, Barrel Switch, 90:1 motor, 50' wire
P-1600AT9	Electric head assembly, Adjustable Tarp Axel, Trombeta Switch, 90:1 motor, 50' wire
P-1600HT9	Electric head assembly, HD Tarp Axel, Trombeta Switch, 90:1 motor, 50' wire
P-1600AR9	Electric head assembly, Adjustable Tarp Axel, Relay switch, 90:1 motor, 50' wire
P-1600HR9	Electric head assembly, HD Tarp Axel, Relay switch, 90:1 motor, 50' wire

* Each kit includes: (1) Stub Shaft 3/4", (1) Bearing 3/4", (2) Bearing Plates

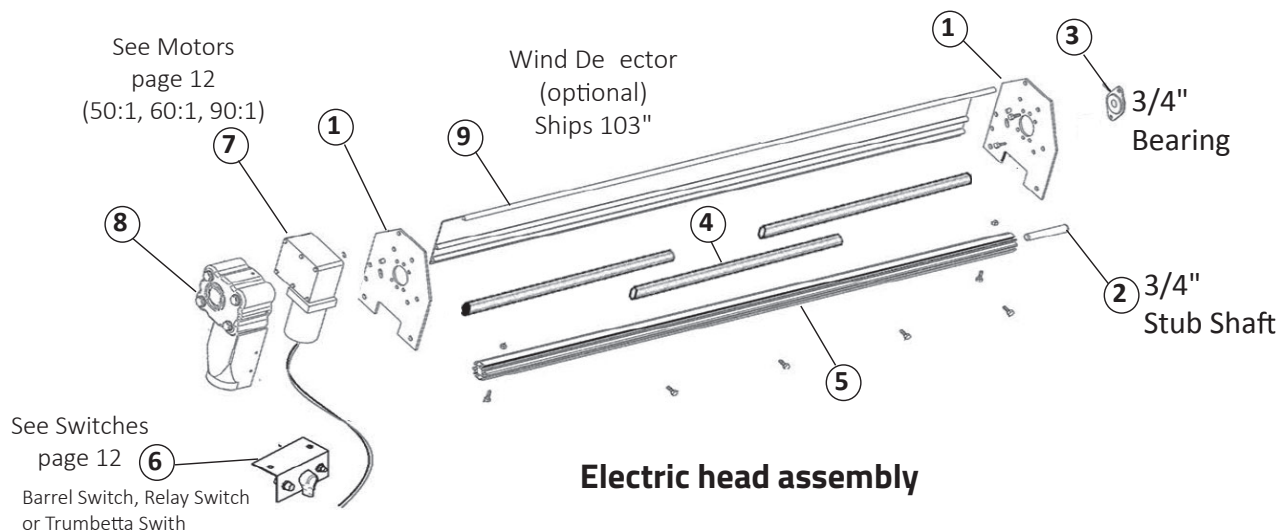



Page Ground level crank box
 Shaft 3/4" w/sprocket
 12' Chain
 Barrel switch kit
 Trombeta switch kit
 Relay switch kit
 50:1 Motor
 60:1 Motor
 90:1 Motor
 50' wire

Conversion kits

P-1410	Ground level conversion kit	19	1	1	1								
P-1650B5	Electric conversion kit: Barrel kit, 50:1 Motor	19				1			1				1
P-1650T5	Electric conversion kit: Trombeta kit, 50:1 Motor	19					1		1				1
P-1650R5	Electric conversion kit: Relay kit, 50:1 Motor	19						1	1				1
P-1650B6	Electric conversion kit: Barrel kit, 60:1 Motor	19				1					1		1
P-1650T6	Electric conversion kit: Trombeta kit, 60:1 Motor	19					1				1		1
P-1650R6	Electric conversion kit: Relay kit, 60:1 Motor	19						1			1		1
P-1650B9	Electric conversion kit: Barrel kit, 90:1 Motor	19				1						1	1
P-1650T9	Electric conversion kit: Trombeta kit, 90:1 Motor	19					1					1	1
P-1650R9	Electric conversion kit: Relay kit, 90:1 Motor	19						1				1	1

**customer may consider replacing the rollerbar, bearing and stub shaft which is not included in these kits*

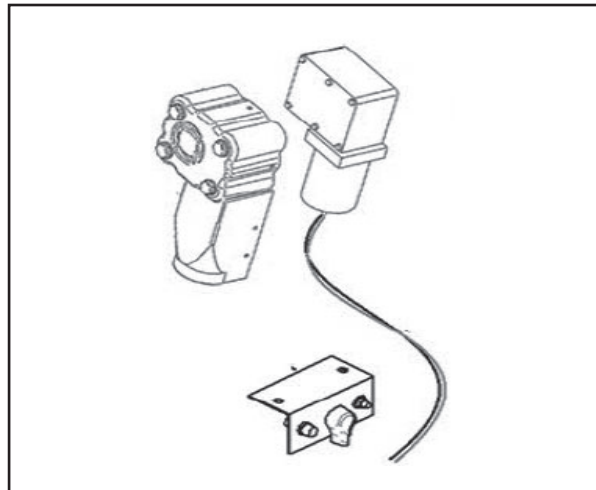



Ground Level Conversion Kit

Part #	Description
P-1410	Ground level conversion kit, GL crank box, 12' #40 chain, Shaft 3/4" with sprocket

Electric Conversion Kit with 50:1 Motor

Part #	Description
P-1650B5	Electric conversion kit: Barrel switch kit, 50' wire, 50:1 Motor
P-1650T5	Electric conversion kit: Trombeta switch kit, 50' wire, 50:1 Motor
P-1650R5	Electric conversion kit: Relay switch kit, 50' wire, 50:1 Motor

Electric Conversion Kit with 60:1 Motor

Part #	Description
P-1650B6	Electric conversion kit: Barrel switch kit, 50' wire, 60:1 Motor
P-1650T6	Electric conversion kit: Trombeta switch kit, 50' wire, 60:1 Motor
P-1650R6	Electric conversion kit: Relay switch kit, 50' wire, 60:1 Motor

Electric Conversion Kit with 90:1 Motor

Part #	Description
P-1650B9	Electric conversion kit: Barrel switch kit, 50' wire, 90:1 Motor
P-1650T9	Electric conversion kit: Trombeta switch kit, 50' wire, 90:1 Motor
P-1650R9	Electric conversion kit: Relay switch kit, 50' wire, 90:1 Motor

Hardware

Part #	Description
P-1002	Hardware bag for GL and Motor



Tarp Kits



Galvanized Steel Tarp System

Page 23

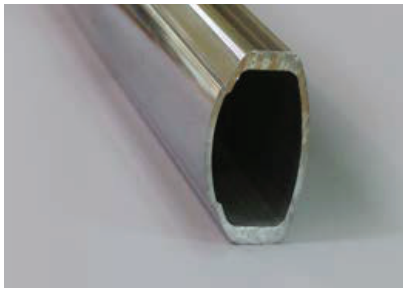

Polished Aluminum Tarp System

Page 24

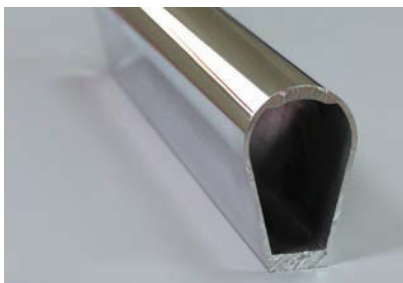

Aero Aluminum Tarp System

Page 26



Heavy Duty Polished Aluminum

Page 28



Galvanized Steel Tarp System

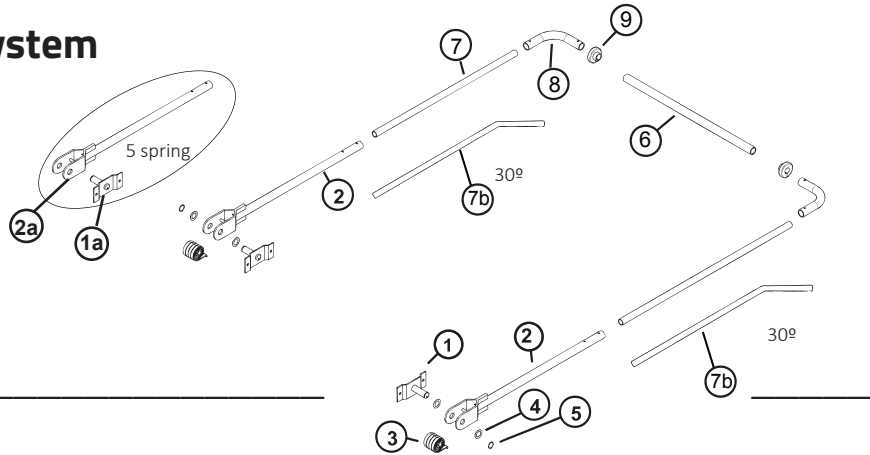

Systems

Part #	Description
T4T-S23EL	4-spring, Steel, Electric (P-1600AB6), system complete with adjustable tarp axel, up to 23'
T4T-S23ELB	4-spring, Steel, Electric (P-1600AB6), system complete with 30 degree bent arms 18" from the end, adjustable tarp axel, covers up to 22' 9"
T4T-S23GL	Steel, manual GL crank (P-1500A), system complete, with adjustable tarp axel, up to 23'
T4T-S23GLB	Steel, manual GL crank (P-1500A), system complete, with 30 degree bent arms 18" from the end, adjustable tarp axel, covers up to 22' 9"

Arm Set

Part #	Description
T4T-S23arms	Galvanized rear arm set complete to cover up to 23'
T4T-S23armsB	Galvanized rear arm set complete w/30 degree bend to cover up to 23'
T4T-LSAK	Lower Steel Arm Kit - everything in the drawing except #6 and #7. Qty 2 - 90 degree corners and Qty 2 tarp centering flanges. Just add upper arms and rear cross piece. Save the freight to ship long pipe. *30 degree bend will decrease the maximum covering distance buy a couple inches.

#	Part #	Description
1	P-2010	4-Spring Pivot Pin
1a	P-2009	5-Spring Pivot Pin
2	P-2036	4-Spring lower Steel arm, 36" length
2	P-2070	4-Spring lower Steel arm, 70" length
2a	P-2075	5-Spring lower Steel arm, 89" length
3	P-S121	Spiral torsion spring - complete system requires Qty 8 - 10
4	P-2040	Stainless steel bushing for pivot pin - complete system requires Qty 4
5	P-2042	Snap ring/Retaining ring for pivot pin, 1.25" - complete system requires Qty 2
6	P-2050	Steel Rear Cross Tube 96" length
7	P-2065	Steel Upper Side Arm, 93" length
7b	P-2065B	Steel Upper Side Arm, 93" length WITH 30 degree bend 18" from end
7	P-2060	Steel Upper Side Arm, 120" length
7b	P-2060B	Steel Upper Side Arm w/ 30 degree bend 18" from end , 120" length
8	P-2055	QTY 1 - Steel 90 degree corner - requires Qty2
9	P-2056	Tarp Centering Flange - plastic
	P-2002	Harware kit for steel system

*Arms must overlap by minimum 18" - 24" * Recommended arm overlap 24"

**The length of the bed will be twice the length of the arm need to cover it not including the overlap



Polished Aluminum 4 Spring Tarp System

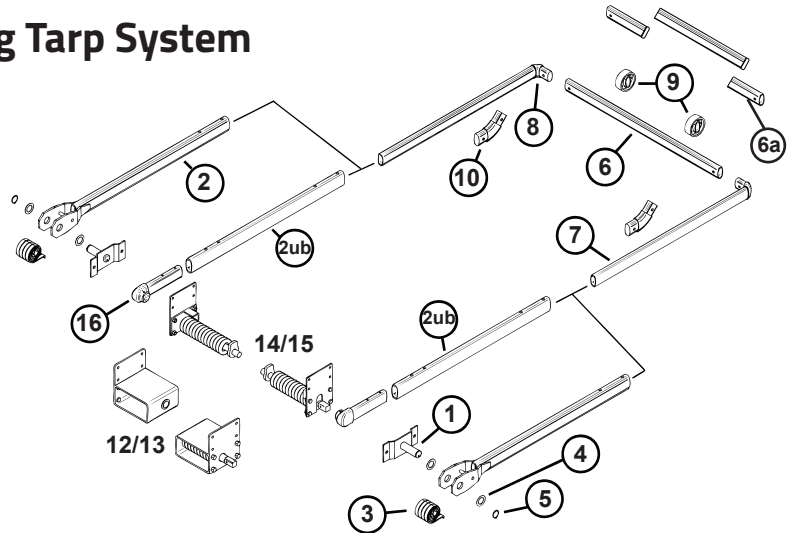
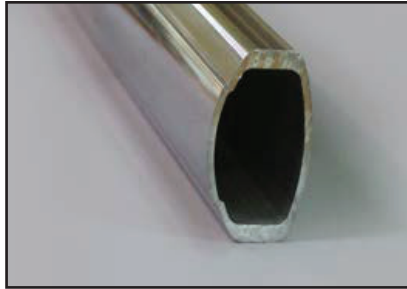

Systems

Part #	Description
T4T-AL23EL	4-Spring Aluminum, Electric (P-1600AB6), system complete with adjustable tarp axel, covers up to 23'
T4T-AL23GL	4-Spring Aluminum, Ground level operation (P-1500A), system complete, with adjustable tarp axel, covers up to 23'

Arm Set

Part #	Description
T4T-AL23arms	Polished Aluminum rear arm set complete- cover bodies up to 23'

#	Part #	Description
1	P-2010	4-Spring Pivot Pin
2	P-3060	4-Spring lower Aluminum Arm, 70" length
3	P-S121	Spiral torsion spring - complete system requires Qty 8
4	P-2040	Stainless steel bushing for pivot pin - complete system requires Qty 4
5	P-2042	Snap ring/Retaining ring for pivot pin, 1.25" - complete system requires Qty 2
6	P-3100	Rear Cross Tube, Aluminum, 103" long
6a	P-3100A	Adjustable Rear Cross Tube, 93-103" long
7	P-3093	Upper Side arm, aluminum, 93" w/90° corner, up to 20' bodies w/60" lower
7b	P-3103	Upper Side arm, aluminum, 103" w/90° corner, up to 20' bodies w/60" lower
8	P-3104	QTY 1 - 90 degree corner - Aluminum
9	P-3110	QTY 1 - Plastic Tarp Centering flange
10	P-3145	QTY 1 - Optional Aluminum 45 degree ELBOW ONLY
10-KIT	P-3145-kit	45 degree elbow kit with hardware
10	P-3130	QTY 1 - Optional Aluminum 30 degree -ELBOW ONLY
10-KIT	P-3130-kit	30° Elbow kit with hardware
	P-3002	Harware kit for aluminum system

*Arms must overlap by minimum 18" - 24" * Recommended arm overlap 24"

**The length of the bed will be twice the length of the arm need to cover it not including the overlap

Standard Aluminum Trailer systems with UB Springs

Systems

Part #	Description
T4T-AL25-UB	Complete electric system to cover up to 25' with UB Springs
T4T-AL35-UB	Complete electric system to cover up to 35' with UB Springs
T4T-AL40-UB	Complete electric system to cover up to 40' with UB Springs

Arm Set

Part #	Description
T4T-AL25arms-UB	Arm set to cover up to 25' with UB springs (84" lower and a 93" upper arm)
T4T-AL35arms-UB	144" lower and a 93" upper covers 35'
T4T-AL40arms-UB	144" lower with 120" upper covers 40'

**30 degree bend will decrease the maximum covering distance buy a couple inches.*

Part #	Description
P-5002AL	Hardware kit UB Standard Aluminum System

Standard aluminum lower arms for use with Underbody springs

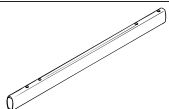
#	Part #	Description	
2ub	P-3312	POLISHED ALUMINUM LOWER ARM 144" FOR UB SPRING BOX	
2ub	P-3307	POLISHED ALUMINUM LOWER ARM 84" FOR UB SPRING BOX	

Under Body (10 spring) spring boxes

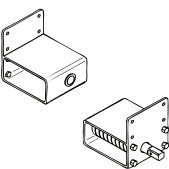
#	Part #	Description	
14/15	P-5010	Underbody 10 spring box passenger side and drivers side set	
14	P-5010P	Underbody 10 spring box passenger side	
15	P-5010D	Underbody 10 spring box drivers side	
	P-5010shaft	Underbody 10 spring box - spring shaft	

Under Body (UB) Single coil spring boxes

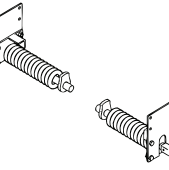
#	Part #	Description	
12/13	P-5020	Underbody SINGLE COIL spring box passenger side and drivers side set	
12	P-5020P	Underbody SINGLE COIL spring box passenger side	
13	P-5020D	Underbody SINGLE COIL spring box drivers side	
	P-5020DS	Underbody SINGLE COIL "spring only" - Driver side	
	P-5020PS	Underbody SINGLE COIL "spring only" - Passenger side	
	P-5020shaft	Underbody SINGLE COIL - spring shaft	

Lower arm connectors

#	Part #	Description	
16	P-5030	Lower arm connector for Aluminum tarp arm	



Aero Aluminum Tarp System

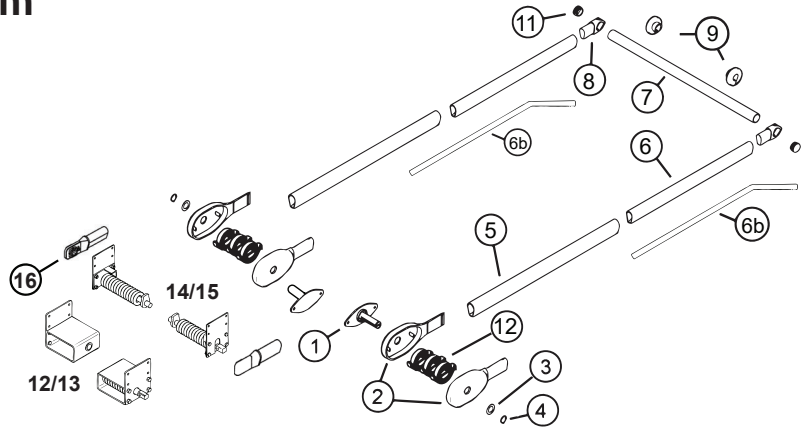
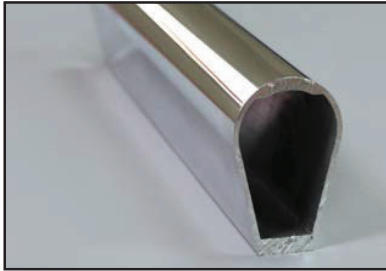

Systems

Part #	Description
T4T-AE22ELB	Electric Tarp System Complete (P-1600AR9), Aero Arm set w/54" upper bent arm, Adjustable Tarp Axel, Relay switch, 90:1 motor w/5 yr warranty and covers up to 22' bodies
T4T-AE-26ELB	Electric Tarp System Complete (P-1600AR9), Aero Arm set w/54" upper bent arm, Adjustable Tarp Axel, Relay switch, 90:1 motor w/5 yr warranty and covers up to 26' bodies

Arm Set

Part #	Description
T4T-AE22armsB	Aero rear arm set complete (lower arms 89", upper arms 54" w/bend), covers up to 22'
T4T-AE-26armsB	Aero rear arm set complete (lower arms 123", upper arms 54" w/bend), covers up to 26'

***swap out 54" upper with bend for 54" upper without bend no charge**
*** 15" minimum overlap on upper and lower arms**

#	Part #	Description
1	P-860237	Aero Pivot Arm Mounting pin
2	P-964022	AE power pack casting kit
3	P-680411	Aero 1.25" flat washer
4	P-2042	Snap ring/Retaining ring for pivot pin, 1.25"
5	P-861802	Aero swing arm, lower 62", covers bodies 10-13' in length
5	P-861803	Aero swing arm, lower 89", covers bodies 14-21' in length
5	P-861804	Aero swing arm, lower, 123" length
6	P-861812	Aero swing arm, upper, 54" length no bend
6b	P-863624	Aero swing arm, upper, 54" length with 30 degree bend
7	P-860706	Aero steel rear cross piece 107.5"
8	P-861151	Aero steel upper arm end, connects rear cross piece to upper arm
9	P-862277	QTY 1 - Rubber Tarp Centering Flange
11	P-862135	QTY 1 - Aero Plug end - for part 0311-861151
	P-619550	Aero side mount Double torsion spring; requires Qty 6

Dump trailer - UB spring and system parts

#	Part #	Description
5	P-861805	Aero swing arm, lower 150", covers bodies 26-28' in length
5	P-861807	Aero swing arm, lower 215", covers bodies 33-40' in length
5	P-861808	Aero swing arm, lower 240", covers bodies 41-49' in length
7	P-860706	Aero steel rear cross piece 107.5"
8	P-861151	Aero steel upper arm end, connects rear cross piece to upper arm
9	P-862277	QTY 1 - Rubber Tarp Centering Flange
11	P-862135	QTY 1 - Aero Plug end - for part 0311-861151

UB spring boxes and replacment parts

#	Part #	Description	
16	P-964103	LOWER ARM CONNECTOR, casting, U/M end fitting	

5-SPRING UB BOX

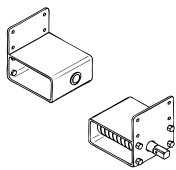
#	Part #	Description	
14/15	P-960420	5 spring underbody spring box assembly -pair (Driver & Passenger side)	
15	P-960414	5 spring underbody spring box assembly (Driver side)	
14	P-960415	5 spring underbody spring box assembly (Passenger side)	
	P-862667	Shaft for 5 spring underbody spring box	
	P-602903	Brass bushing for 5 spring underbody spring box	
	P-602115	Bearing 1.25" for 5 spring underbody spring box	

SINGLE SPRING UB BOX

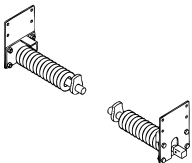
#	Part #	Description	
12/13	P-864103	Spring assembly; U/M 5/8" pair (DS & PS) 18'-40'	
13	P-960346	Spring assembly; U/M 5/8" DS Steel 18'-40'	
12	P-960347	Spring assembly; U/M 5/8" PS Steel 18'-40'	
	P-860452	Shaft; for 5/8" spring	

Other parts

Part #	Description
P-860530	Rear cross arm; 98" alum for 96" wide trailers
P-863014	Casting, upper S/A corner
P-862272	Bumper, rubber; 4" for alum upper arm; w/groove
P-863615	132" lower arm extrusion to be used with tripple lower LWR

*Manufacturer requires a minimum of a 15" arm overlap from lower and upper side arms

**the length of the bed will be twice the length of the arm need to cover it not including the overlap



Heavy Duty Polished Aluminum

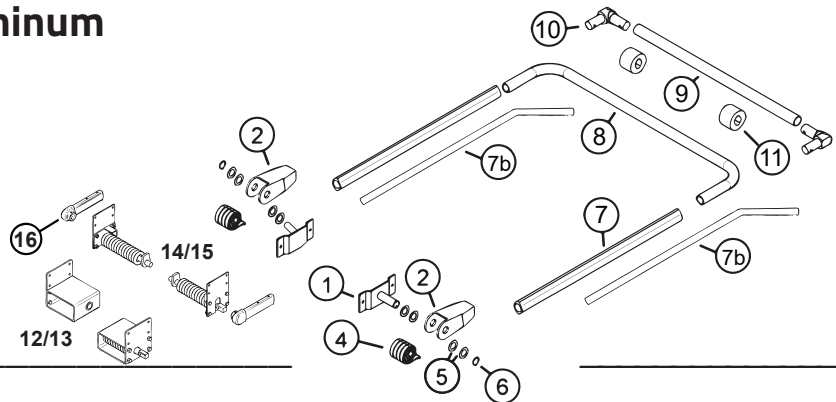

Systems

Part #	Description
T4T-HD20ELB	4-spring Electric (P-1600HR9) external mount HD Aluminum system complete, 120" side arms w/30 degree bend, HD tarp axel, covers bodies up to 20'*
T4T-HD24ELB	4-spring Electric (P-1600HR9) external mount HD Aluminum system complete, 144" side arms w/30 degree bend, HD tarp axel, covers bodies up to 24'*

Arm Set

Part #	Description
T4T-HD20armB	4-spring external mount HD Aluminum arm set, 120" side arms w/30 degree bend, bodies up to 20'*
T4T-HD24armsB	4-spring external mount HD Aluminum arm set, 144" side arms w/30 degree bend, bodies up to 24'*

***30 degree bend will decrease the maximum covering distance buy a couple inches.**

1	P-2010	4-Spring Pivot Pin
2	P-4010	4-Spring external mount casting for HD Aluminum Arm
4	P-S121	Spiral torsion spring
5	P-2040	Stainless steel bushing for pivot pin
6	P-2042	Snap ring/Retaining ring for pivot pin, 1.25"
7	P-4120	HD Aluminum Arm, 120" length for body up to 20'
7b	P-4120B	HD Aluminum Arm, 120" length for body up to 20' w/30 degree bend
7	P-4144	HD Aluminum Arm, 144" length for body up to 24'
7b	P-4144B	HD Aluminum Arm, 144" length for body up to 24' w/30 degree bend
7	P-4168	HD Aluminum Arm, 168" length for body up to 26'
7b	P-4168B	HD Aluminum Arm, 168" length for body up to 26' w/30 degree bend
7	P-4192	HD Aluminum Arm, 192" length for body up to 32' - two piece arm
7b	P-4192B	HD Aluminum Arm, 192" length for body up to 32' w/30 degree bend
7	P-4240	HD Aluminum Arm, 240" length for body up to 40'
7b	P-4240B	HD Aluminum Arm, 240" length for body up to 40' w/30 degree bend
	P-4210	Two piece arm connector for HD Aluminum arm 16' and longer
8	P-4102	Steel Cross Tube - 1 piece 102" wide for 96" wide body
8	P-4108	Steel Cross Tube - 1 piece 110" wide for 102" wide body
9	P-4096	Steel Cross Tube, 98" length (requires Qty 2 - 90 degree corners Part #4098)
10	p-4098	QTY 1 - 90 degree casting for HD Aluminum arm
11	P-4095	QTY 1 - 3" rubber tarp centering flange for steel rear cross piece
	P-4002	Harware kit for HD aluminum system
	P-2045	Brass Bushing



HD Aluminum arm sets with UB springs cover up to 40'

Systems

Part #	Description
T4T-HD20-B-UB	Complete System for up to 20' body with head assembly (part#P-1600HR9) and UB Arm set (part# T4T-HD20armB-UB) below
T4T-HD24-B-UB	Complete System for up to 24' body with head assembly (part#P-1600HR9) and UB Arm set (part# T4T-HD24armB-UB) below
T4T-HD28-B-UB	Complete System for up to 28' body with head assembly (part#P-1600HR9) and UB Arm set (part# T4T-HD28armB-UB) below
T4T-HD32-B-UB	Complete System for up to 32' body with head assembly (part#P-1600HR9) and UB Arm set (part# T4T-HD32armB-UB) below

Arm Set

Part #	Description
T4T-HD20armB-UB	Arm set for up to 20' - HD Aluminum Arm set with 5/8" UB springs, lower arm connectors, 3 piece cross piece, rubber bumpers and 12' arms w/bend
T4T-HD24armB-UB	Arm set for up to 24' - HD Aluminum Arm set with 5/8" UB springs, lower arm connectors, 3 piece cross piece, rubber bumpers and 10' arms w/bend
T4T-HD28armB-UB	Arm set for up to 28' - HD Aluminum Arm set with 5/8" UB springs, lower arm connectors, 3 piece cross piece, rubber bumpers and 12' arms w/bend
T4T-HD32armB-UB	Arm set for up to 32' - HD Aluminum Arm set with 5/8" UB springs, lower arm connectors, 3 piece cross piece, rubber bumpers and 12' arms w/bend

***30 degree bend will decrease the maximum covering distance buy a couple inches.**

Part #	Description
P-5002HD	Hardware kit for UB HD Aluminum System

Under Body (10 spring) spring boxes

#	Part #	Description	
14/15	P-5010	Underbody 10 spring box passenger side and drivers side set	
14	P-5010P	Underbody 10 spring box passenger side	
15	P-5010D	Underbody 10 spring box drivers side	
	P-5010shaft	Underbody 10 spring box - spring shaft	

Under Body (UB) Single coil spring boxes

#	Part #	Description	
12/13	P-5020	Underbody SINGLE COIL spring box passenger side and drivers side set	
12	P-5020P	Underbody SINGLE COIL spring box passenger side	
13	P-5020D	Underbody SINGLE COIL spring box drivers side	
	P-5020DS	Underbody SINGLE COIL "spring only" - Driver side	
	P-5020PS	Underbody SINGLE COIL "spring only" - Passenger side	
	P-5020shaft	Underbody SINGLE COIL - spring shaft	

Lower arm connectors

#	Part #	Description	
16	P-5040	Lower arm connector for HD Aluminum Tarp Arm	



Side-to-Side Tarp Data Form Manual System

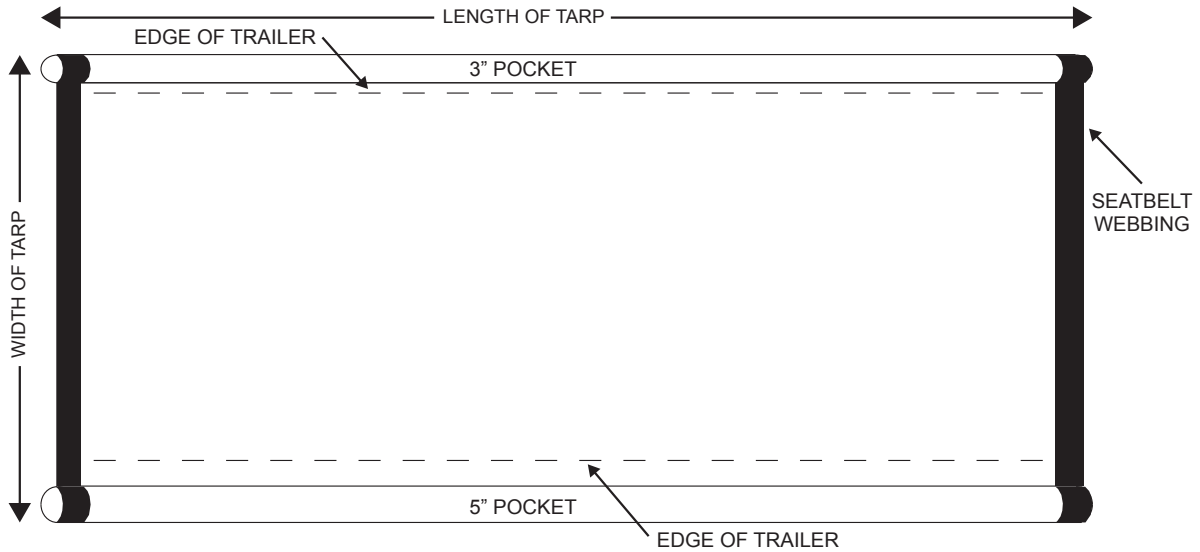

Trailer dimensions: Width _____ Length _____

For **Custom Tarp Quotes and Orders** please fill in the following Dimensions:
Please draw in or mark up any other changes in order for us to quote and produce the tarp to your specifications.

Dim 1 _____ Finished size width of tarp
Dim 2 _____ Finished size length of tarp

Options:

Dim 3 _____ Front flap - draw in and list dimension
Dim 4 _____ Rear flap - draw in and list dimension
Dim 5 _____ Optional reinforcements - make notes on drawing

Material Selection:

- 18 oz Vinyl
Black, unless otherwise stated
- 22 oz Vinyl
Black, unless otherwise stated
- Mega Mesh™ *
- Other _____

* Color will vary

Customer Information

Date: _____

- This is a Quote
- This is an Order

Name: _____

Contact: _____

Contact Phone Number: _____

All custom tarps require a signed drawing:

Customer Signature

Signature states you agree to the design and to the pricing. No Returns on special size tarps.



Side-to-Side Tarp Data Form Automatic System

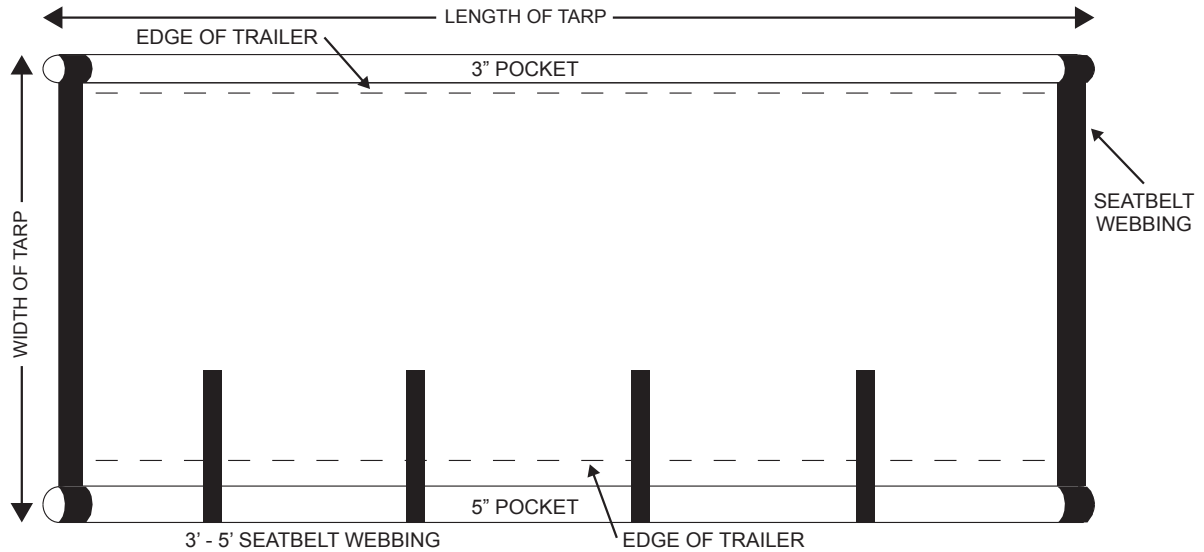

Trailer dimensions: Width _____ Length _____

For **Custom Tarp Quotes and Orders** please fill in the following Dimensions:
Please draw in or mark up any other changes in order for us to quote and produce the tarp to your specifications.

Dim 1 _____ Finished size width of tarp
Dim 2 _____ Finished size length of tarp

Options:

Dim 3 _____ Front flap - draw in and list dimension
Dim 4 _____ Rear flap - draw in and list dimension
Dim 5 _____ Optional reinforcements - make notes on drawing

Material Selection:

- 18 oz Vinyl
Black, unless otherwise stated
- 22 oz Vinyl
Black, unless otherwise stated
- Mega Mesh™ *
- Other _____

* Color will vary

Customer Information

Date: _____

This is a Quote

This is an Order

Name: _____

Contact: _____

Contact Phone Number: _____

All custom tarps require a signed drawing:

Customer Signature

Signature states you agree to the design and to the pricing. No Returns on special size tarps.



Front-to-Rear Tarp Data Form

Standard Multi-Color Mesh specifications

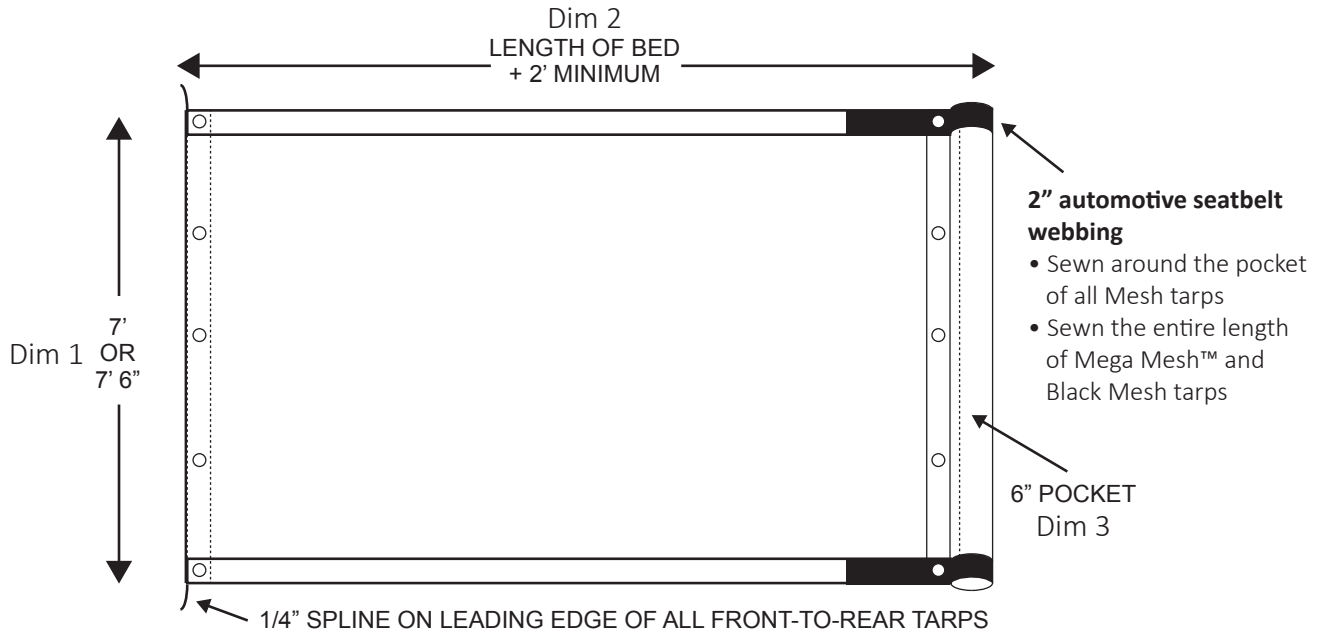

For **Custom Tarp Quotes and Orders** please fill in the following Dimensions:

Please draw in or mark up any other changes in order for us to quote and produce the tarp to your specifications.

Dim 1 _____ Finished size width of tarp

Dim 2 _____ Finished size length of tarp

Dim 3 _____ Width of pocket (6" standard spec)

Dim 4 _____ Grommet spacing down the side of the tarp
(Standard spec is NO grommets down the side hems)

Material Selection:

- Multi-Color PVC Mesh *
- Heavy Duty Black PVC Mesh
- Mega Mesh™ *
- 18 oz Vinyl
- Asphalt Lumite
- Other _____

* Color will vary

Pricing

Price Calculation: _____ X _____ X _____ = _____

Width
Length
Price per sq.ft.
Tarp Cost

(add 1" to finished size)
(add 1" to finished size)
(page 10)

Customer Information

Date: _____ Name: _____

This is a Quote Contact: _____

This is an Order Contact Phone Number: _____

All custom tarps require a signed drawing:

Customer Signature

Signature states you agree to the design and to the pricing. No Returns on special size tarps.



Cable System Tarp Data Form

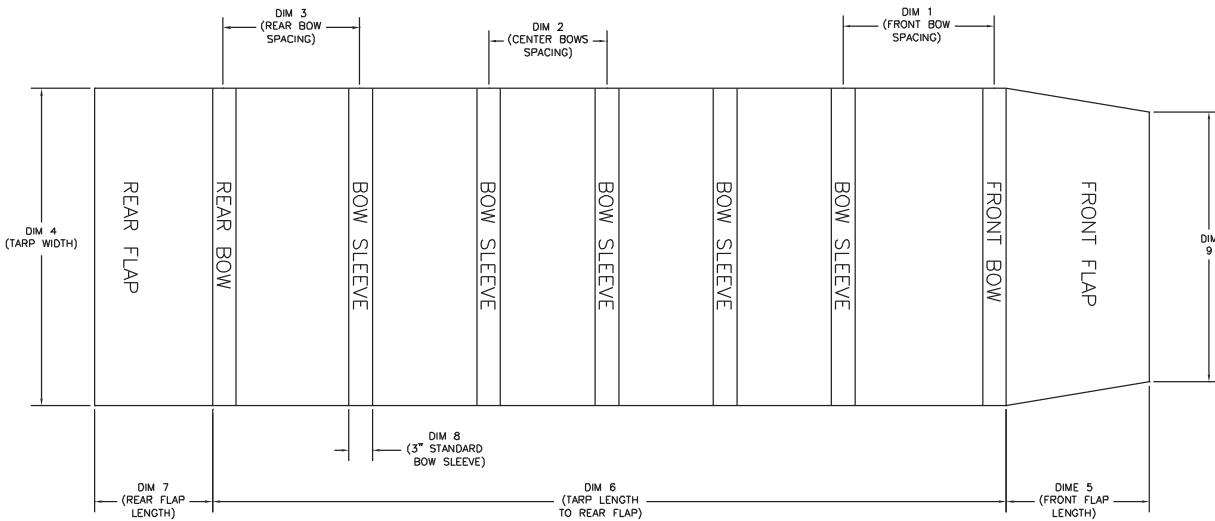

Bow Arch _____" = Height of the bows
Bed Width _____" = Inside to inside of body at narrowest point of top rail or boards
Bed Length _____" = Measure from point where tarp is mounted at front to furthest point where last bow can slide

Style: Anti-pollution Semi-waterproof

Number of Bow Pockets Required

Pocket Spacing: Dim 1 _____ Dim 2 _____ Dim 3 _____
 Width & Length: Dim 4 _____ Dim 5 _____ Dim 6 _____
 Dim 7 _____ Dim 8 _____

Note: 18 oz Black Vinyl material used unless otherwise specified. No Grommets unless specified.

Customer Information

Date: _____ Name: _____
 This is a Quote Contact: _____
 This is an Order Contact Phone Number: _____
 All custom tarps require a signed drawing:

Customer Signature

Signature states you agree to the design and to the pricing. No Returns on special size tarps.



Switch Wiring Diagrams

Rotary or Barrell Switch Kit

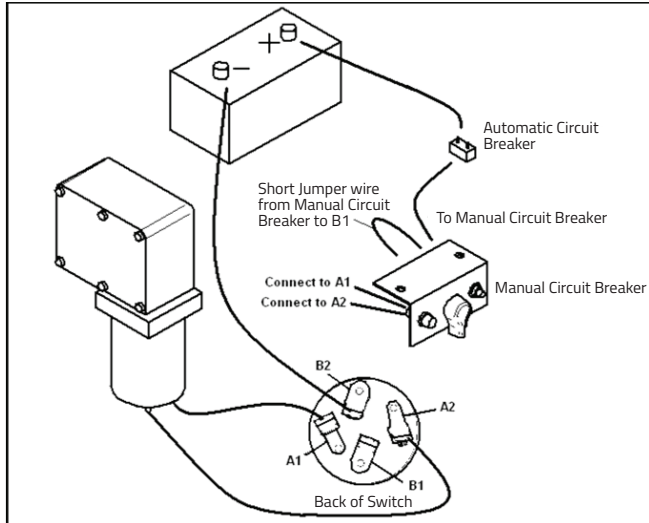

Relay Switch Kit

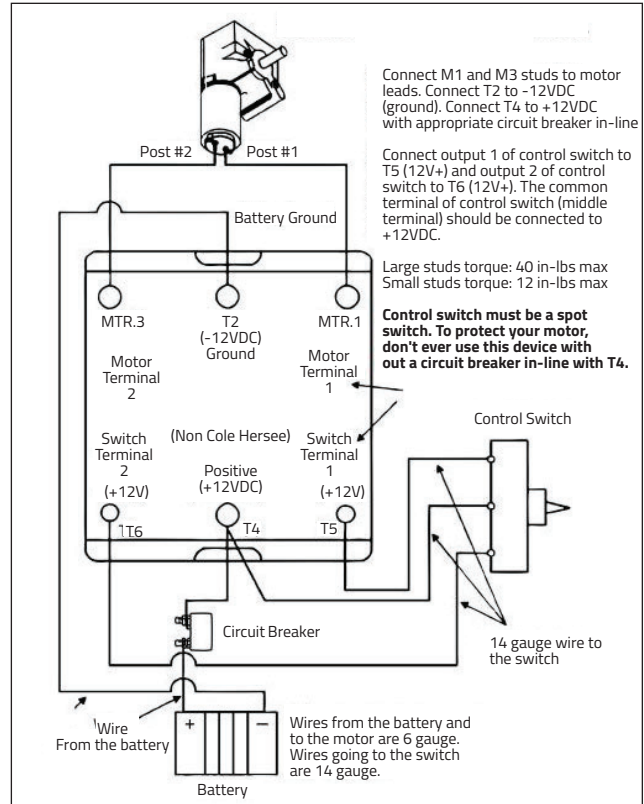

Trombetta Switch Kit

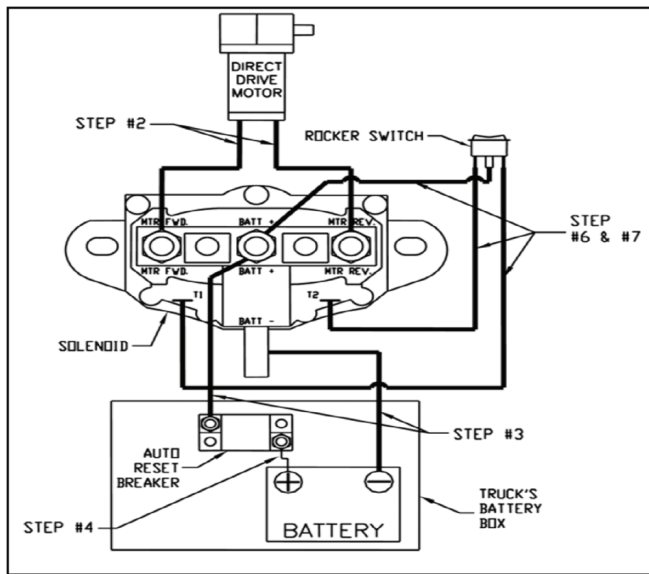

See page 12 for part #s and pricing



- Tarps4Trucks is the only judge of warranty and we reserve the right to repair, replace or issue a credit for any product found to be under warranty.
- No freight on lumber tarps, lumber tarp dollars do not count toward free freight totals.
- Our tarps are warranted against defects in material and workmanship for 90 days.

Florida Free freight policy:

- \$1,000 free freight on orders that fit on a standard 4' pallet (tarps, motors, switches, springs, adjustable roller bars, small parts)
 - \$2,000 free freight for orders that fit on a pallet less than 144" long but longer than 4' long
 - No free freight for orders that ship longer than 12' - please call for quote
- **No free freight on lumber tarps, lumber tarp costs do not count toward free freight total

South Eastern United States Free freight policy:

- \$2,000 free freight on orders that fit on a standard 4' pallet (tarps, motors, switches, springs, adjustable roller bars, small parts)
 - \$3,000 free freight for orders that fit on a pallet less than 144" long but longer than 4' long
 - no free freight for orders that ship longer than 12' - please call for freight quote.
- **No free freight on lumber tarps, lumber tarp costs do not count toward free freight total

Motor Warranty Process

- Motor warranties are covered by the original manufacturer
- Requires a Return Authorization Number prior to shipping the item back. Please call 863-676-2579.
- End user or dealer is responsible for this freight.
- Motor will have to be inspected before a warranty decision can be made; could take weeks.
- ONLY a Tarps4Trucks representative can authorize a motor warranty.
- Tarps4Trucks reserves the right to replace a motor, issue a credit or provide a new motor found under warranty.
- Warranty left on the original motor would be transferred to the replacement motor.

Return & Refund Policy

Returns:

A full credit for the item will be applied to your in-house account to be used for any future purchases as long as it meets the following guidelines:

- To be eligible for a return, your item must be unused and in the same condition that you received it and able to be sold again as a new product. Provided it is "like new" we will issue full credit (see refund section for full details)
- If the item is not "like new" there will be a 10% restocking fee, we will not accept damaged or broken items that cannot be re-sold.
- Must be an item we still carry or manufacture.
- No refunds or returns will be given on special made to order tarps, bee nets, hammocks, shades, parts or accessories.

Shipping:

- You will be responsible for paying for your own shipping costs for returning your item. Original shipping costs are non-refundable.

Refunds:

- Once we receive your item, we will inspect it and notify you that we have received your returned item. We will notify you on the status of your refund after inspecting the item. If eligible you will receive a full refund towards future purchases.
- Refund amount will be the original price paid (less the cost of shipping if applicable) or the current sale price, whichever is less at time of return.

We reserve the right to refuse any returns or make any changes to our return policy at any given time.

Other

- Minimum order of \$50, we reserve the right to round up any invoices under \$50 to \$50.
- Tarps4Trucks is willing to swap out parts that are kept in original packaging, purchased less than 90 days earlier, and that are still offered for sale at their full value.
- **No Free Freight on Lumber Tarps.**

Our Team



Matt Tyree
 Tennessee, Virginia,
 Northern Mississippi,
 Northern Alabama
 (727) 403-1933
 matt@tritonheavyduty.com

Chad Tyree
 North Carolina & South Carolina
 813-428-2081
 chad@tritonheavyduty.com
 matt@tritonheavyduty.com

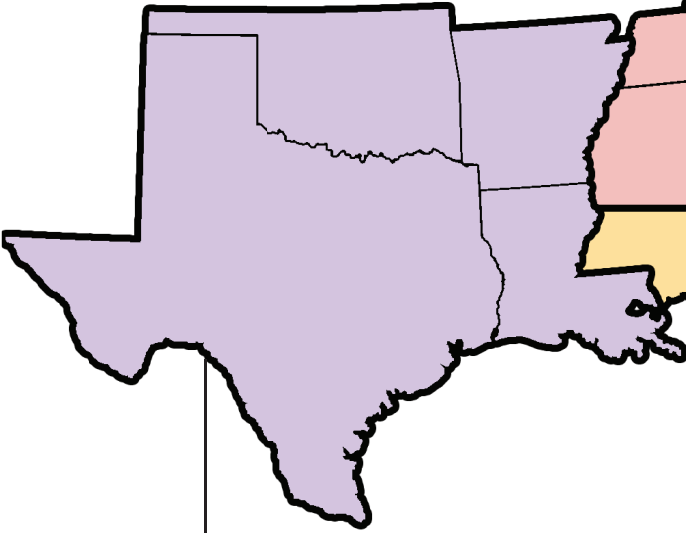

Jon Cabino
 Texas, Oklahoma, Arkansas,
 Louisiana
 (727) 542-1022
 jon@tritonheavyduty.com
 matt@tritonheavyduty.com

Ryan Lincoln
 Georgia, Jacksonville, Panhandle,
 South Mississippi, South Alabama
 (607) 331-6141
 ryan@tritonheavyduty.com
 matt@tritonheavyduty.com

Phil Bruno
 Central and South Florida
 561-307-7808
 phil@tritonheavyduty.com
 matt@tritonheavyduty.com



- Hand Tarps
- Asphalt Tarps
- RFL Tarps
- Lumber Tarps
- Roll Off Tarps
- Side 2 Side Tarps
- Sod Tarps
- Compactor Diaper
- Container Liners
- Bungee Staps
- Bee Nets
- Wind Screen
- Privacy Fence
- Primate Hammocks
- Fixed Boat Tarps



PROUDLY MADE IN FLORIDA, USA BY

Tarps4Trucks

a *Cosner Mfg.* company